

# Shear deformation analysis for woven fabrics

Huiyu Sun <sup>\*</sup>, Ning Pan

*Department of Biological and Agricultural Engineering, University of California, Davis, CA 95616, USA*

Available online 8 February 2004

## Abstract

A new mechanical model is proposed in this paper to evaluate the shearing properties for woven fabrics during the initial slip region. Compared to the existing mechanical model for fabric shear, this model involves not only bending but also torsion of curved yarns. This model has the advantage of taking into consideration the yarn undulation in fabrics while keeping mathematical rigor. Moreover, an erroneous formula in the previous research work from a referenced paper is modified. Analytical results show that this model provides better agreement with the experiments for both the initial shear modulus and slipping angle than the existing model. The approach for this model can be extended to predict other mechanical properties of fabrics in order to obtain more precise results. © 2004 Elsevier Ltd. All rights reserved.

*Keywords:* Plain-weave fabrics; Shear deformation; Undulation geometry; Yarn slippage

## 1. Introduction

Automation of the handling and transport of apparel fabrics is of vital interest to industrialized nations, where the cost of labor is a significant portion of the total product cost. A thorough understanding of the shearing behavior is very important for designing automated process to handle fabrics. The ability of a fabric to shear deformation is a particularly important forming characteristic, which enables the manufacture of 2-dimensional preforms into complex 3-dimensional shapes. Shearing of fabrics is a major deformation mode during draping [1]. This involves not only in-plane rotation of the yarns at the cross-over of the weave mainly, but also yarn slips. Good draping leads to the fitting of a fabric over a surface without undesirable wrinkling and tearing.

In undergoing an investigation of fabric shearing, it was initially suggested by Mack and Taylor [2] that a fabric behaves as a pin-jointed mesh, whereby the tows rotate or trellis about the fabric cross-over. Lindberg et al. [3] studied the behavior of fabrics in shear. On the basis of analysis of experimental shear stress/strain curves they pointed out that the shear deformation

generally goes through three stages: initially shear without yarn sliding followed by shear with sliding, and then jamming. Shear deformation is initially resisted by friction at warp and weft cross-over points and then elastic forces when two yarn systems approach jamming. Depending on the values of the friction and tightness of weave, the shear stress/strain curve of a fabric presents particular features. By further assuming that the yarns are inextensible and incompressible, Grosberg and Park [4] proceeded to analyze the modes of deformation involved in shearing of plain woven fabrics in terms of the mechanical properties of yarns and the geometrical parameters of the fabric. In the work of Skelton [5], the limits of shear deformation were determined by various geometrical parameters of the fabric, and different limiting configurations were reached in fabrics of various types. Approximate relationships were derived which permitted the estimation of the shear stiffness and the shear limits from readily available fabric data.

Kawabata et al. [6] used a different approach to obtain the relationship between the shear force and shear angle. Instead of using a complete theoretical analysis, they proposed a linear approximation where the torque required for changing shear angle was assumed to be a simple summation of a constant initial torque, a friction resistance item and an elastic resistance item. Both of the latter items are linear function of the shear angle. All the coefficients in the formula were determined from experiments.

<sup>\*</sup> Corresponding author. Tel.: +1-530-752-8984; fax: +1-530-752-7584.

*E-mail address:* [hsun@ucdavis.edu](mailto:hsun@ucdavis.edu) (H. Sun).

Assuming that the initial response of a unit fibrous cell to an externally applied shear stress involves both the bending of fiber sections and slippage at contact regions, Pan and Carnaby [7] derived the total proportion of slipping and non-slipping contact regions using the density function of fiber orientations within the unit fibrous cell. By considering a plain-weave unit cell and assuming that yarn rotation about the region of overlaps behaves as a pin-jointed mesh, Prodromou and Chen [8] provided a geometric model to predict the occurrence of fabric lock-up.

Asvadi and Postle [9] used linear viscoelastic theory to analyze fabric shear behavior under high shear strain conditions. They presented a quantitative study of the viscoelastic response and the frictional stress of woven fabrics under large strain shear deformation. Sinoimeri and Drean [10] applied energy methods to predict shear behaviors of a plain-weave fabric. They added a rheological model in the analysis to account for possible slippage between threads at cross-over contact regions. The computed stress–strain curves were reported to be similar in shape to those observed in experiments.

Hu and Zhang [11] analyzed the stresses developed in a KES test and concluded that, due to the presence of corners and both tensile and shear stresses, the specimen is not subjected to pure and uniform shear. A finite element analysis yielded a distribution of shear stress along the clamping direction, where the shear stress varied from zero at the corners to a maximum in the middle of the specimen. Recent work by Page and Wang [12] first considered a uniform shear state of the fabric and the relationship of shear force versus shear angle was established, then explored a non-uniform shear state and the manner in which a change of the shear angle could affect the yarn slippage was indicated. In the

analysis both the beam-deflection theory and finite element methods were used.

Using fabric geometric and material parameters, Nguyen et al. [13] predicted the initial slip region of the fabric as well as the more dominant elastic deformation range. Mohammed et al. [14] employed the continuum mechanics approach to analyze shear deformation and micromechanics of woven fabrics. A regression analysis was carried out to determine some parameters for the shear stress–strain relationship from the experimental data.

In this paper, a mechanical model based on the shear deformation modes by Grosberg and Park [4] for woven fabrics is proposed. The mechanical model takes into account the yarn undulation, which was previously ignored to avoid mathematical complexity. In addition, this paper modifies an erroneous formula for the frictional moment between warp and weft yarns at cross-over regions during shearing [4]. The mechanical model developed in this paper gives better theoretical results than the previous model comparing to the experiments.

## 2. Theoretical analysis

Fig. 1(a) shows a representation of a fabric deformed in a square shear rig. As the fabric material is sheared, the forces acting on the bar linkage can be resolved into shear and tensile force components acting perpendicular and parallel to the fabric yarn (Fig. 1(b)). At small angle of shearing, the acting tensile force component will have negligible magnitude and hence can be ignored (Fig. 1(c)). Shearing in a plain-weave fabric occurs by the relative movement of two sets of yarns, warp and weft, which are interlaced in a one-up and one-down fashion.

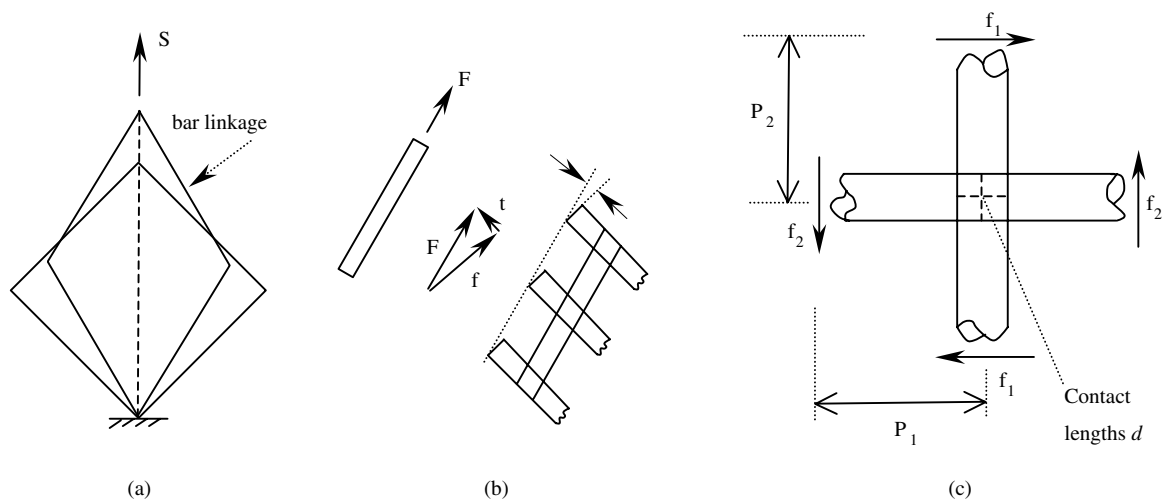

Fig. 1. (a) Fabric shearing under applied load  $S$ . (b) The shearing forces acting along the bar linkage  $F$  can be resolved into components of tension  $t$  and shear  $f$  acting parallel and perpendicular to the tows. (c) For the unique case of the initial slip region as the shear angles are assumed to be small, the fabric can be idealized to be in a state of pure shear.

Because of the bending resistance of the yarns, which form the fabric, the yarn exerts a pressure at the cross-over joints, which, in turn, produces a frictional resistance to shearing. Grosberg and Park [4] demonstrated that the modes of deformation involve several forms depending upon the degrees of shear imposed upon the fabric. These are:

- (1) deformation due to rigid intersections when the shear force is too small to overcome the friction;
- (2) yarn slippage at the intersection. This only takes place when the shear force overcomes the friction;
- (3) an elastic deformation when slipping is complete;
- (4) jamming in the structure.

The geometry of the woven fabric under consideration here is shown in Fig. 2. The initial unloaded yarn geometry is assumed to be a sequence of alternating circular arcs of constant radius  $R$ . With reference to Fig. 2(a), the usual geometrical weave parameters of pick spacing  $P$ , yarn length  $l$  and crimp height  $h$  are represented in terms of the radius  $R$  and crimp angle  $\phi_0$  by

$$\begin{aligned} P &= 2R \sin \phi_0 \\ l &= 2R\phi_0 \\ h &= 2R(1 - \cos \phi_0) \end{aligned} \tag{1}$$

And

$$\phi_0 = \alpha + \beta, \quad \beta = \frac{d}{2R} \tag{2}$$

where the angle  $\alpha$  corresponds to the non-contact segment of curved yarns, the angle  $\beta$  corresponds to the

contact segment of yarns with a length of  $\frac{d}{2}$ , and  $d$  is the contact length of yarns.

### 2.1. Deformation due to rigid intersections

If a shear force is applied which is less than the frictional restraint at the intersecting points, the fabric should behave like an elastic grid structure whose joints are welded at the contact points. Because the joint behaves as if welded for these extremely small deformations (order of  $0.05^\circ$  of shearing), each beam deforms as a cantilever. With reference to Fig. 2(b), the bending and torsional moments at any cross-section  $D$  within the non-contact segment of curved yarns with an angle  $\varphi$  due to the external force  $f$  and the imaginary external couple  $M_a$  applied at the end of the curved cantilever are

$$\begin{aligned} M_x &= -fR \sin(\alpha - \varphi) - M_a \cos(\alpha - \varphi) \\ M_z &= fR[1 - \cos(\alpha - \varphi)] + M_a \sin(\alpha - \varphi) \end{aligned} \tag{3}$$

The strain energy for the curved non-contact segment of yarns can be determined as

$$U = \int_0^\alpha \left( \frac{M_x^2}{2EI_x} + \frac{M_z^2}{2C} \right) R d\varphi \tag{4}$$

where  $E$  is the elastic modulus of the yarn,  $I_x$  is the inertia moment of the yarn cross-section about the axis  $x$ ,  $C$  is the torsional rigidity about the axis  $z$ .

According to the theorem of Castigliano, the rotational angle about the axis  $x$  at the end of the curved cantilever is given by

$$\delta = \left. \frac{\partial U}{\partial M_a} \right|_{M_a=0} \tag{5}$$

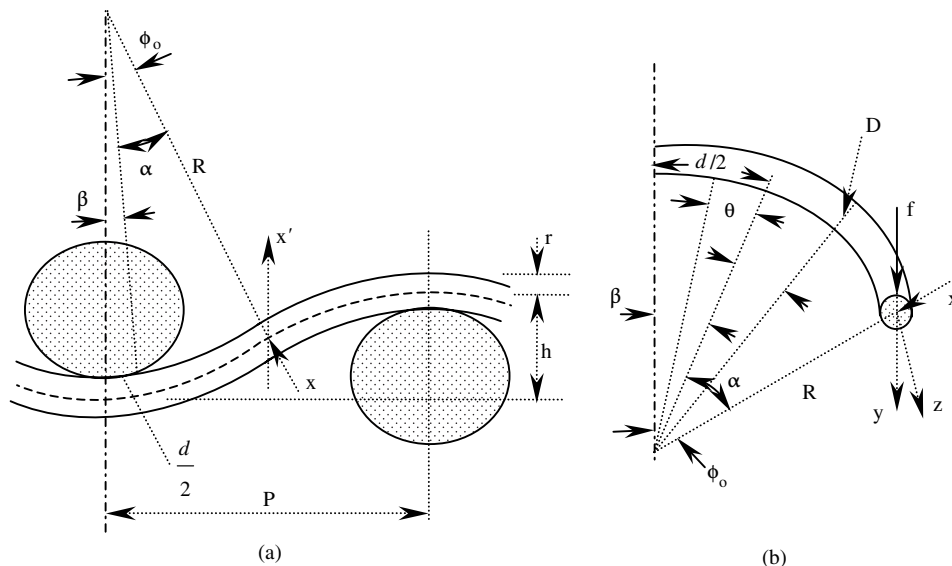

Fig. 2. (a) Cross-section of weave in either warp or weft direction. (b) Schematic of an undulant yarn loaded by a force  $f$ .

Substituting Formula (3) into (5) leads to

$$\begin{aligned} \delta &= \int_0^\alpha \left[ \frac{M_x}{EI_x} \frac{\partial M_x}{\partial M_a} + \frac{M_z}{C} \frac{\partial M_z}{\partial M_a} \right] R d\varphi \Big|_{M_a=0} \\ &= \int_0^\alpha \left[ \frac{fR \sin(\alpha - \varphi)}{EI_x} \cos(\alpha - \varphi) \right. \\ &\quad \left. + \frac{fR[1 - \cos(\alpha - \varphi)]}{C} \sin(\alpha - \varphi) \right] R d\varphi \\ &= fR^2 \left[ \frac{\sin^2 \alpha}{2EI_x} + \frac{(1 - \cos \alpha)^2}{2C} \right] \end{aligned} \quad (6)$$

The rotational angle about the axis  $x'$  (cf. Fig. 2) is obtained.

$$\delta' = fR^2 \cos \phi_0 \left[ \frac{\sin^2 \alpha}{2EI_x} + \frac{(1 - \cos \alpha)^2}{2C} \right] \quad (7)$$

If the yarn is assumed to be an isotropic material with a circular cross-section, then

$$C = GI_p = 2GI_x = \frac{EI_x}{(1 + \nu)}, \quad I_x = \frac{\pi r^4}{4}$$

Where  $G$  is the shear modulus of the yarn cross-section,  $I_p$  is the polar moment of inertia about the axis  $z$ ,  $\nu$  is the Poisson's ratio for the yarn and  $r$  is the yarn radius. Another form of the formula (7) can be got

$$\delta' = \frac{fR^2 \cos \phi_0}{2EI_x} [\sin^2 \alpha + (1 + \nu)(1 - \cos \alpha)^2] \quad (8)$$

### 2.2. Yarn slippage at the intersecting region

From the work of Grosberg and Park [4], it is assumed that

- (1) the total contact pressure is distributed triangularly over the contact region (Fig. 3(a));
- (2) the contact at the intersection is a line contact;
- (3) and slippage takes place gradually from the outer boundary of the contact to the inner boundary.

The normal contact force is approximately given by [4]

$$V = 16EI_x \frac{\sin \phi_0}{P^2} \quad (9)$$

According to the pressure distribution shown in Fig. 3(a), the normal pressure at any angular position  $\varphi$  is

$$v(\varphi) = v_0 \frac{\varphi R}{\frac{d}{2}} = \frac{V}{\frac{d}{2}} \cdot \frac{\varphi R}{\frac{d}{2}} = \frac{V\varphi}{\beta^2 R} \quad (10)$$

When the portion from 0 to  $\theta$  can slip (while the portion from  $\theta$  to  $\beta$  remains as if welded), the frictional moment is obtained as follows:

$$\begin{aligned} M &= \mu \int_0^\theta \frac{V\varphi}{\beta^2 R} \left[ 2R \sin \left( \frac{\theta - \varphi}{2} \right) \right] R d\varphi \\ &= \frac{4\mu VR}{\beta^2} \left( \theta - 2 \sin \frac{\theta}{2} \right) \end{aligned} \quad (11)$$

With reference to Fig. 3(b) for the problem dealt with by Grosberg and Park [4], the frictional force on the domain  $dx$  is  $\frac{V}{d} \left( 1 - \frac{2x}{d} \right) dx$ . But the arm of the frictional force should be  $\left[ x - \left( \frac{d}{2} - \frac{a}{2} \right) \right]$ , not  $x$ . So the frictional moment for the problem should be modified as

$$M = \mu \int_{\frac{d}{2} - \frac{a}{2}}^{\frac{d}{2}} \frac{V}{d} \left( 1 - \frac{2x}{d} \right) \left[ x - \left( \frac{d}{2} - \frac{a}{2} \right) \right] dx = \frac{\mu V d}{24} \left( \frac{a}{d} \right)^3 \quad (12)$$

For the problem tackled in this paper, in case the undulant radius of warp yarns is not equal to that of the weft yarns, the frictional moment is taken as an average of the two possible values

$$M = \frac{2\mu V(R_1 + R_2)}{\beta^2} \left( \theta - 2 \sin \frac{\theta}{2} \right) \quad (13)$$

where the subscripts 1 and 2 denote the warp and weft directions, respectively.

On the other hand, the external moment due to the shear force is also taken as an average of the two possible values, that is

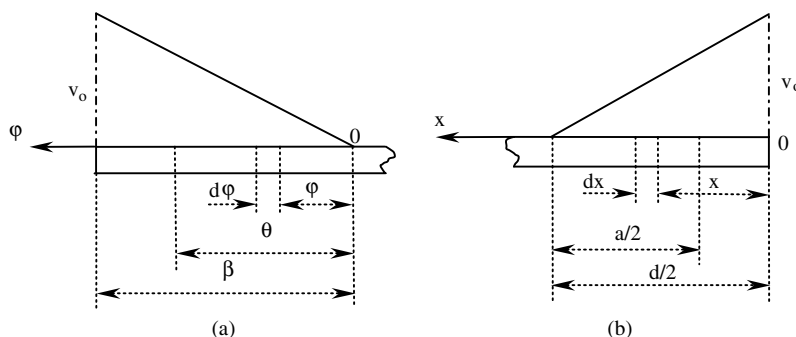

Fig. 3. (a) Contact pressure distribution with angular position. (b) Contact pressure distribution with yarn length for Ref. [4].

$$\begin{aligned}
 M &= \frac{1}{2}(M_1 + M_2) \\
 &= \frac{1}{2} \left[ f_2 \cdot 2R_1 \sin \left( \frac{\alpha_1 + \theta}{2} \right) + f_1 \cdot 2R_2 \sin \left( \frac{\alpha_2 + \theta}{2} \right) \right] \\
 &= \frac{F}{L} \left[ P_2 R_1 \sin \left( \frac{\alpha_1 + \theta}{2} \right) + P_1 R_2 \sin \left( \frac{\alpha_2 + \theta}{2} \right) \right] \quad (14)
 \end{aligned}$$

Considering slippage equilibrium, the external moment should be equal to the frictional moment. From Formulas Eqs. (13) and (14), the shear force is obtained.

$$F = \frac{\frac{2\mu V(R_1+R_2)}{\beta^2} (\theta - 2 \sin \frac{\theta}{2})}{\frac{1}{L} [P_2 R_1 \sin \left( \frac{\alpha_1 + \theta}{2} \right) + P_1 R_2 \sin \left( \frac{\alpha_2 + \theta}{2} \right)]} \quad (15)$$

From Eq. (7), substituting  $(\alpha + \theta)$  for  $\alpha$ , the shear angle  $\gamma$  is got.

$$\begin{aligned}
 \gamma &= \delta'_1 + \delta'_2 \\
 &= \frac{F}{L} \left\{ P_2 R_1^2 \cos \phi_{01} \left[ \frac{\sin^2(\alpha_1 + \theta)}{2E_1 I_{x1}} + \frac{[1 - \cos(\alpha_1 + \theta)]^2}{2C_1} \right] \right. \\
 &\quad \left. + P_1 R_2^2 \cos \phi_{02} \left[ \frac{\sin^2(\alpha_2 + \theta)}{2E_2 I_{x2}} + \frac{[1 - \cos(\alpha_2 + \theta)]^2}{2C_2} \right] \right\} \quad (16)
 \end{aligned}$$

Because yarn slippage takes place gradually from the outer boundary of the contact to the inner boundary,  $\theta$  varies from 0 to  $\beta$  in above formulas.

### 3. Results and discussion

To investigate the effectiveness of the mechanical model, the analysis discussed in Section 2 is used to model the initial slip region during shearing of plain-weave dry fabrics. The plain-weave fabrics configurations considered and their corresponding geometric and material properties required for the model are given in Table 1. Fabric geometric properties were obtained from observations using a stereo microscopic [13].

Figs. 4 and 5 show the corresponding shear force and shear angle relationship for plain-weave fabrics of 1 and 3 K tow sizes with a diameter of 8  $\mu\text{m}$  for each filament, respectively, for the initial slip region. The theoretical results modeled in this paper are compared with those in

Table 1  
Main parameters for woven fabrics [13]

Parameters	Units	PW (1 K)	PW (3 K)
$P_1$	mm	1.58	2.13
$P_2$	mm	1.52	2.16
$L$	mm	240	240
Yarn thickness	mm	0.08	0.11
$d$	mm	0.48	0.52
$E$	GPa	210	220
$G$	GPa	5.5	5.5

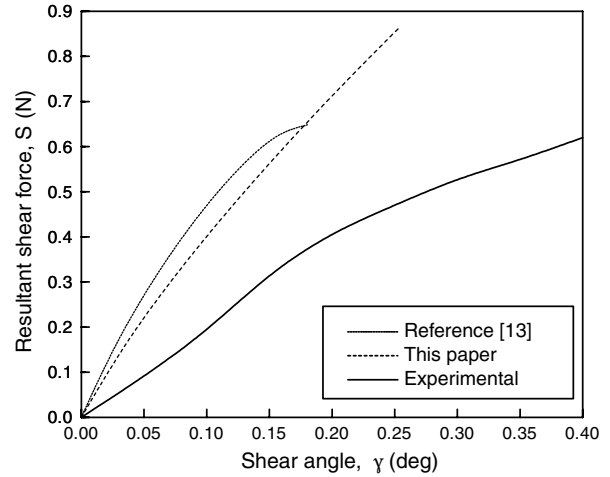

Fig. 4. Relationship between shear force and shear angle at the initial slip region for plain-weave fabrics of 1 K tow size.

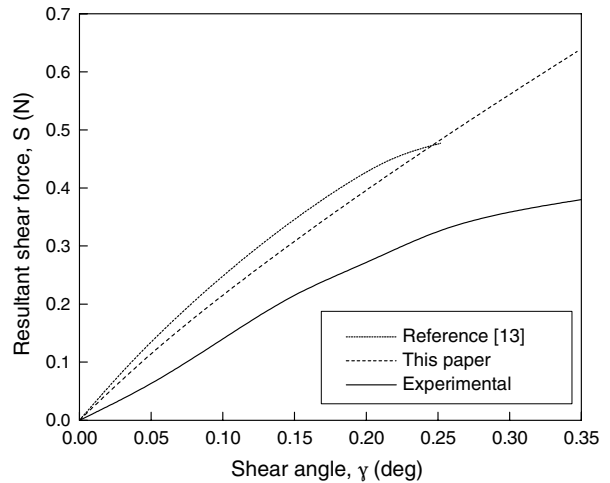

Fig. 5. Relationship between shear force and shear angle at the initial slip region for plain-weave fabrics of 3 K tow size.

Ref. [13] as well as the experimental results. It is shown that the results given in this paper yield better agreement than those in Ref. [13].

Using linear interpolation, Table 2 shows the average predicted shear modulus and slip region in comparison with the experimental values for this fabric deformation zone. Again, the modeling results from this paper for both shear modulus and slip region are better than those in Ref. [13]. Yet, the model proposed in this paper needs to be further improved for more precise analysis for the shear deformation of woven fabrics.

### 4. Conclusions

Considering the undulation of yarns in a fabric, a mechanical model for initial shear deformation is

Table 2  
Predicted and experimental shear moduli and angles of shear for the initial slip region

	Shear modulus (N/deg)			Slip region (deg)		
	Ref. [13]	This paper	Experiment	Ref. [13]	This paper	Experiment
PW (1 K)	3.6	3.4	2.5	0 → 0.18	0 → 0.25	0 → 0.40
PW (3 K)	1.9	1.8	1.4	0 → 0.25	0 → 0.35	0 → 0.35

proposed in this paper. This model *more closely reflects* the reality of woven fabrics *compared* to the model by Grosberg and Park, and produces better agreement with experiments than the existing results.

Further investigation needs to be undertaken to improve this mechanical model in order to give more precise results.

### Acknowledgements

Acknowledgement is due to the National Textile Center for supporting this program of research.

### References

- [1] Potter KD. The influence of accurate stretch data for reinforcements on the production of complex structural mouldings. Part 1. Deformation of aligned sheets and fabrics. *Composites* 1979;10(3):161–7.
- [2] Mack C, Taylor HM. The fitting of woven cloth to surfaces. *J Textile Inst* 1956;47(2):T477–88.
- [3] Lindberg J, Behre B, Dahlberg B. Shearing and buckling of various commercial fabrics. *Textile Res J* 1961;31:99–122.
- [4] Grosberg P, Park BJ. The mechanical properties of woven fabrics. Part V. The initial modulus and the frictional restraint in shearing of plain weave fabrics. *Textile Res J* 1966;36:420–31.
- [5] Skelton J. Fundamentals of fabric shear. *Textile Res J* 1976;46:862–9.
- [6] Kawabata S, Niwa M, Kawai H. The finite deformation theory of plain-weave fabrics. Part III. The shear-deformation theory. *J Textile Inst* 1973;64(2):62–85.
- [7] Pan N, Carnaby GA. Theory of the shear deformation of fibrous assemblies. *Textile Res J* 1989;59(5):285–92.
- [8] Prodromou AG, Chen J. On the relationship between shear angle and wrinkling of textile composite preforms. *Composites: Part A* 1997;28A:491–503.
- [9] Asvadi S, Postle R. An analysis of fabric large strain shear behavior using linear viscoelasticity theory. *Textile Res J* 1994;64(4):208–14.
- [10] Sinoimeri A, Drean JY. A study of the mechanical behavior of the plain-weave structure by using energy methods: fabric shear. *J Textile Inst* 1996;87(1):120–9.
- [11] Hu JL, Zhang YT. The KES shear test for fabrics. *Textile Res J* 1997;67(9):654–64.
- [12] Page J, Wang J. Prediction of shear force and an analysis of yarn slippage for a plain-weave carbon fabric in a bias extension state. *Compos Sci Technol* 2000;60:977–86.
- [13] Nguyen M, Herszberg I, Paton R. The shear properties of woven carbon fabric. *Compos Struct* 1999;47:767–79.
- [14] Mohammed U, Lekakou C, Dong L, Bader MG. Shear deformation and micromechanics of woven fabrics. *Composites: Part A* 2000;31:299–308.